

## 40GBase-eSR4 QSFP+ Transceiver

### Descriptions:

- 10-Gbps × 4-Ch Duplex
- 300 / 400-m Link Length via OM3/OM4
- Power Level 1 Compliance
- Full Digital Diagnostics Interface
- Electrical Hot-Plug Compatible
- Standard 12/8 lane optical fiber with MPO pluggable optical connector
- 0 to 70°C case temperature operating range
- RoHS Compliance and Lead-Free



### Certifications:

- Ethernet Packet Test Passed
- Entire Characterization Test Passed
- Full Reliability Test Passed

### Applications:

- 40GBASE-SR4 Ethernet links
- InfiniBand QDR, DDR, and SDR
- 4G/8G/10G Fiber Channel
- SATA/SAS Storage
- HPC Interconnects
- Proprietary Interconnections

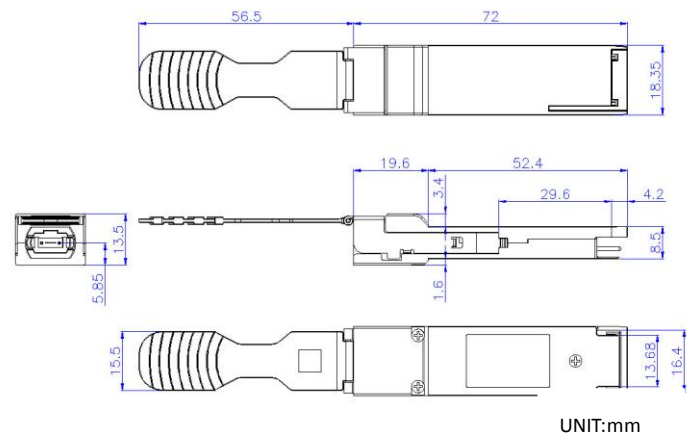

### Product Selection:

P/N	Data Rate (Gbps)	TX	RX	TX(dBm)		Reach	Temperature (deg C)	Description
				Min	Max			
C04010QTXM300	40	850 VCSEL	PIN	-7.6	2.4	300m	0~70	QSFP e-SR4